

Honeywell

Bendix/King Avionics

OB2106-001/2

CONTROL PANEL

INSTALLATION MANUAL

MANUAL NUMBER OB2202-001

**THIS MANUAL HAS BEEN COMPILED IN ACCORDANCE
WITH THE GENERAL REQUIREMENTS OF BCAR A7-4.**

CAA DESIGN APPROVAL NO DAI/9536/96

ELECTRONIC DOCUMENT DETAILS		
NETWORK PATH AND FILE NAME	FILE TYPE/VERSION	PRINTER
\\Gate\released_dwgs\Observer MrkII+\Manual\OB2202-001 Rev 2	Microsoft® Word	Network

HARD DOCUMENT DETAILS				
REVISION	DOI No.	ORIGINATOR	DESCRIPTION of CHANGE	DATE
01	OB2+_Log161	Mel White	Initial Issue PROVISIONAL	27/07/05
02	DOI 151	Chris Connelly	Update to reflect MKII+ system	27/07/05

DOCUMENT APPROVAL

Authorised for Release for and on Behalf of Skyforce Avionics Limited:



.....
Steve White – Hardware Design Specialist

NOTICES

PROPRIETARY NOTICE

The information disclosed within this document or separately supplied in furtherance of this document includes proprietary rights of Skyforce Avionics Ltd. and Honeywell International Inc. Neither this document nor the information disclosed herein or of a supplementary nature shall be reproduced or transferred to other documents or used or disclosed to others for manufacturing purposes, or for any other purposes, except as specifically authorised in writing by Skyforce Avionics Ltd. or Honeywell International Inc. Skyforce Avionics Ltd. is a subsidiary of Honeywell International Inc. Copyright 2005 Honeywell International Inc. All rights reserved.

TRADEMARK NOTICE

“Skyforce” and the Skyforce logo are registered trademarks of Honeywell International Inc., U.S. and UK Patent & Trademark Office’s.

FLIGHT MANUAL

The information contained with this manual is for reference use only. If any information herein conflicts with similar information contained within the Aeroplane Flight Manual Supplement, the information in the Aeroplane Flight Manual Supplement shall take precedence.

CONTACT ADDRESS

Skyforce Avionics Limited
5 the Old Granary
Boxgrove, Chichester
West Sussex
PO18 0ES
Tel: 44 (0) 1243 783763
Fax: 44 (0) 1243 783992
Email: sales@skyforce.co.uk

Honeywell International Inc.
One Technology Center
23500 West 105th Street
Olathe, Kansas
USA 66061-1950 USA
Tel: 001 913 712 2613
Fax: 001 913 712 1302
Email: bendixking@honeywell.com

CONTENTS

1	INTRODUCTION.....	4
2	DESCRIPTION.....	4
2.1	MECHANICAL DESCRIPTION.....	4
2.2	ELECTRICAL DESCRIPTION.....	4
2.3	MISSION DATA LOADING.....	5
2.3.1	<i>RS232 INTERFACE</i>	5
2.3.2	<i>LINEAR PCMCIA INTERFACE</i>	5
2.3.3	<i>ETHERNET INTERFACE</i>	5
3	GENERAL INSTALLATION CONSIDERATIONS	6
3.1	SCHEDULE OF PARTS	6
3.2	SYSTEM COOLING REQUIREMENTS	6
3.3	COMPASS SAFE DISTANCE	6
3.4	SPECIAL TOOLING	6
3.5	MATERIALS	6
4	INSTALLATION CHECK OUT	7
4.1	NORMAL OPERATION	7
4.1.1	<i>POWER ON</i>	7
4.1.2	<i>SHUT-DOWN</i>	8
4.1.3	<i>MISSION DATA LOADING</i>	8
4.1.4	<i>ABNORMAL OPERATION</i>	9
5	DRAWINGS & SCHEMATICS.....	10
6	APPENDIX A - ENVIRONMENTAL.....	15
6.1	SCHEDULE OF TESTS.....	15
7	APPENDIX B - WARRANTY	16
7.1	DEFINITIONS.....	16
7.2	STANDARD WARRANTY	16
7.3	MAINTENANCE.....	17
7.4	USE AND CONTROL OF DATA AND HARDWARE	17
7.5	GOVERNING LAW	18

END OF SECTION

1 INTRODUCTION

The OB2106 Control Panel is an integral part of Mk II and Mk II+ Observer, providing the switch on point for the system. It is both a distribution box for keyboard clock/data/power and a user mission data loader point. Keyboard controlling devices that can be connected to the Control Panel include the OB1108 Hand Remote Controller, OB1302 Keyboard, OB1305 Backlit Keyboard, OB1303 Series Dzus Controllers and the integral 5 soft keys and joystick controls that are built into the OB1110 6.4" Display/Control Head and compatible products.

This installation manual describes the functionality of the OB2106 Control Panel and details its installation requirements. Furthermore it explains how the functionality of the unit may be proven in the aircraft installation. It, however, assumes that an OB2109 Rack and system interconnect has already been installed on the aircraft under the guidance of the OB2201 Installation Manual.

2 DESCRIPTION

2.1 MECHANICAL DESCRIPTION

The Control Panel is a Dzus rail mounted device that weighs 650g. It has five connectors, three on the front, and two on the rear. The three front connectors comprise SK1 (Keyboard 1) and SK2 (Keyboard 2), which are 7 Way, MIL-C-26482 sockets, and SK3, which is an Ethernet port. The two rear connectors comprise SK4, which is a 7 Way MIL-C-26482 socket, and PL1, which is a 37 Way D Type connector (Keyboards 3 to 7).

2.2 ELECTRICAL DESCRIPTION

As a distribution box for the various keyboards, the Control Panel performs like a "smart controller". In other words it will take the last key press detected from any of its attached keyboards and send this to the Processor. In this way it is the last person to touch a key that has control of the system at any one time. Each keyboard or controlling device derives its power from the Control Panel, either as 5Vdc or 12Vdc. Therefore each controlling device will make four connections to the Control Panel and they are Keyboard Clock, Keyboard Data, Power (either 12Vdc or 5Vdc) and Ground. The controlling device options can be summarised as follows:

Part Number	Mass	Comments
OB1108-002 Hand Remote Controller	230g	Supplied with pre manufactured 7 Way MIL-C-26482 connector for direct connection to SK1 or SK2 or a suitably wired out keyboard from rear of Control Panel
OB1302-003 Keyboard	410g	
OB1305-001 Backlit Keyboard	880g	
OB1303 Dzus Remote Controllers	410g	Refer to pin out details in the OB2201 Installation Manual
OB1110-001 Display/Control Head	1900g	These displays have integral controlling devices. Refer to pin out details in the OB2201 Installation Manual

The pin out information for all these devices is available in the OB2201 Installation Manual for the OB2109 Install Rack & Connections.

2.3 MISSION DATA LOADING

The Control Panel offers three methods of down loading data or interfacing with the OB2101 Processor to which it is connected. Bear in mind not all these options need be connected, the connections will vary from installation to installation. These three methods are as follows.

2.3.1 RS232 INTERFACE

Provided Com 3 of the OB2101 Processor has been connected to PL1 on the rear of the Control Panel, and Com 3 has been configured as a PC Interface, the RS232 interface will be available via SK1. This can be used for communicating with the Processor for up/downloading Flight Plans.

2.3.2 LINEAR PCMCIA INTERFACE

Provided the Canbus interface from the OB2101 Processor has been connected to PL1 on the rear of the Control Panel, the Linear PCMCIA card interface will be available via the front slot. This can be used for downloading User Defined Databases.

2.3.3 ETHERNET INTERFACE

Provided the Ethernet from the OB2101 Processor has been connected to SK4 on the rear of the Control Panel, this interface will be available via the Ethernet connector, SK3, on the front of the Control Panel. This connection will be used for downloading large amounts of memory intensive data.

3 GENERAL INSTALLATION CONSIDERATIONS

The Control Panel has been designed to locate in conventional Dzus rails as indicated by the attached Mechanical Drawing. This is typically mounted within the central console of an aircraft. It is assumed that at this stage (i.e.: Installation Rack and system interconnects are installed), the installation is a case of making connection to the SK4 and PL1 connectors on the rear of the Control Panel and locking the unit into the Dzus rail with a suitable screwdriver.

3.1 SCHEDULE OF PARTS

DESCRIPTION	STOCK No.	DRG No.	PART No.	QTY
CONTROL PANEL(Non NVG)	1020510804		OB2106-001	1
CONTROL PANEL (NVG)	1020511396		OB2106-002	1
12 Mb Linear PCMCIA Card (blank)	3170610587		CM2013	1
Installation Manual			OB2202-001	1

3.2 SYSTEM COOLING REQUIREMENTS

There are no special cooling requirements for the OB2106 Control Panel.

3.3 COMPASS SAFE DISTANCE

The OB2106 Control Panel has been tested and certified in accordance with RTCA/DO-160D Section 15 – Magnetic Effect, Category Z (Less than 30cm).

3.4 SPECIAL TOOLING

No special tools are required for installation of the OB2106 Control Panel.

3.5 MATERIALS

All materials used in the OB2106 Control Panel are non flammable and/or self quenching

END OF SECTION

4 INSTALLATION CHECK OUT

The purpose of this section of the document is to allow the Control Panel's functionality to be proven on the aircraft. It considers a complete utilisation of the Control Panel's functions. The installer is reminded that there are many possible installation configurations for the Control Panel relating to the various types of keyboards and the means of mission data loading; therefore he/she needs to be aware which of these are applicable to the installation in question.

It is assumed that as part of the Install Rack and system interconnects installation the loom that has been fitted to the aircraft, has already been electrically tested end to end on a pin by pin basis using best practice, before connection of the Control Panel and putting any power on the system.

4.1 NORMAL OPERATION

In order to check operation of the Control Panel a Processor will need to be installed. **AT NO TIME THROUGHOUT THE TESTING SHOULD THE PROCESSOR BE REMOVED FROM THE RACK** whilst still powered, since this could damage the system. The Control Panel should be checked out as per the requirements of this installation manual, at a nominal temperature of 20 degree Centigrade, +/- 10deg Centigrade prior to flight clearance. The minimum testing shall be as follows:

4.1.1 POWER ON

Move the switch on the front of the Control Panel to the ON position and check that the Green POWER lamp illuminates above the PCMCIA slot, and that the Amber TEMP lamp is off. Allow the system to boot up (this process should last about 20 seconds), clearing the initial warning screen by selecting OK. Check that all the keys and joysticks operate the system from all the different controlling devices. If the controlling device is a mini keyboard, it is only necessary to check that the F1 to F5 (these mimic the 5 soft keys) and the up/down, left/right cursor keys (these mimic the joystick) operate. Check that the HDD lamp illuminates when panning the map in MAP mode with a joystick. Check that the Control Panel back lighting is adjusted locally by turning the BRT (Brightness) pot. There are two methods to safely shut down the Observer system. If a Control Panel is fitted you can turn the ON/OFF switch to OFF. There will be a warning on the screen stating that the power switch has been turned off and if not turned back on again the system will save any settings and close down. The second method is to carry out a software shutdown. Select Shutdown in the main menu (F1) followed by Yes (F5). Once the screen has gone blank you should then turn the ON/OFF switch on the control panel to OFF (if fitted) or remove power to the Observer Circuit via the Observer Master Switch.

4.1.2 SHUT-DOWN

NOTE

Removing power from the Observer system before the system has completed the shut down operation (all LED's are extinguished) can cause NVM corruption resulting in the system failing to operate correctly.

There are two correct methods of shutting down the Observer system, either through software or from the Control Panel/Display Head.

Software –

Select SHUT DOWN in the MAIN MENU, and then press the YES key. The system will then automatically switch to a black screen, indicating it is now safe to turn the system off at the Control Panel/Display Head. Check that all LED's are extinguished and the display, if wired into the system, is blank. It is then safe to remove power from the system, for example by moving the ON/OFF switch on the Control Panel to the OFF position.

Control Panel/Display Head –

At any time while the system is running, move the ON/OFF switch on the Control Panel/Display Head to the OFF position. The software will detect the shut down request and will prompt the operator "Are you sure?" . Select [YES] and the system will complete the shut down operation. Check that all LED's are extinguished and the display, if wired into the system, is off.



4.1.3 MISSION DATA LOADING

As indicated earlier in this manual there are three methods for mission data loading via RS232, Linear PCMCIA Card and Ethernet. Since the Control Panel simply passes the

RS232 and Ethernet connections through to its front panel these interfaces can be checked out by simply performing an end to end pin out continuity test. The Linear PCMCIA Card interface can be checked since it is preloaded with a TEST User Defined Database. To test this function switch on the system via the Control Panel ON/OFF switch and wait for the system to boot up. The first screen will appear with a PCMCIA UPDATE key. Place the preloaded Linear PCMCIA card, supplied with the Control Panel, into the front slot. Note that this operation should cause the CRD lamp to illuminate. Then press the PCMCIA UPDATE key and follow the instructions given. This operation should detect and load the TEST User Defined Database. Once this is complete press the HELP key to get to Main Menu and then the MAP key to get into Map Mode. Next, with the joystick inactive, select the SEARCH key and scroll down the list of databases until you find one called TEST. Highlight this and press the SELECT key. A TEST USER DEFINED ITEM will appear highlighted. Press the DIRECT TO key and verify that the system returns the user to Map Mode with navigation data to the selected point (even if the system has no GPS input and shows the NO FIX POSSIBLE or NO EXTERNAL POSITION DATA messages).

4.1.4 ABNORMAL OPERATION

The Observer system has a number of enunciators in the Control Panel that advise the user that the Processor is in wait mode or has failed. (PWR) This Green LED will illuminate when the system is selected ON. If it fails to illuminate then the power is not being delivered to the Processor, this can either be through an open circuit C/B or a failure within the OB2101 Processor Box. Alternatively it could be the failure of the LED indicator light, in this eventuality the system will still however run.

(TEMP) This is an Amber coloured lamp. This lamp indicates that the OB2101 Processor Box is operating outside its certified operating range (-20°C to +55°C). In this event the Processor Box will take one to two corrective actions;

- a) System will fail to boot up until temperature falls within operating range
- b) Warning message will be displayed, citing the system will enter a hibernating mode unless temperature falls within operating range. In Hibernating mode the system remains powered but all external communications and raster map access becomes disabled.

In the event that a controlling device is not functioning check that the device is wired correctly and that it is connected to an active keyboard port i.e. Keyboards 1, 3, 4 and 5.

END OF SECTION

5 DRAWINGS & SCHEMATICS

The four pages following this contain released drawings for;

- i. OB2106 Control Box Overall Dimensions,
- ii. OB2106 Control Box Connector Pin Assignment,
- iii. OB2101-001/002/003 Installation Wiring Schematic.

Note

All drawings incorporated herein are available from the factory as *.pdf format files electronically on application to sales@skyforce.co.uk

Please be aware unless you specifically request the issues listed below we will supply the latest Revision of these documents.

This Manual, Page Number	Illustration Description	Available Document Number	Document Revision used to complete this version of the Manual.
10	Observer Control Panel Final Assembly incorporating OB2106-001 and OB2106-002.	10205-11396	1
11	Observer Control Panel Connector Pin Assignment Incorporating OB2106-001 and OB2106-002.	21105-11766	1
12	Installation Wiring Schematic Incorporating OB2101-001 and OB2101-002.	21101-11765 (Page 1)	1
13	Installation Wiring Schematic Incorporating OB2101-003.	21101-11765 (Page 2)	1

Observer Control Panel Final Assembly (Incorporating OB2106-001 & OB2106-002).

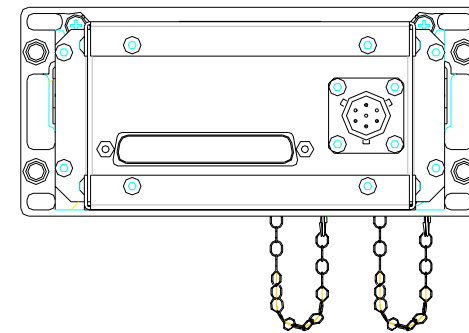
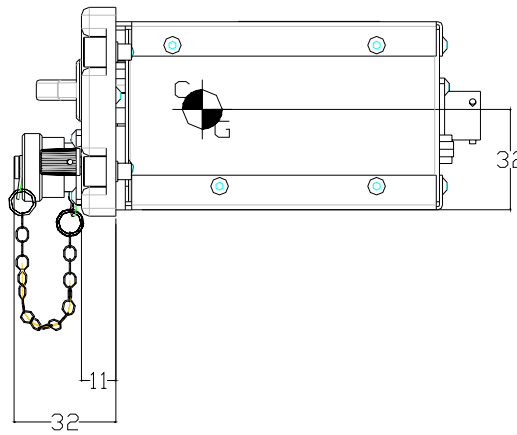
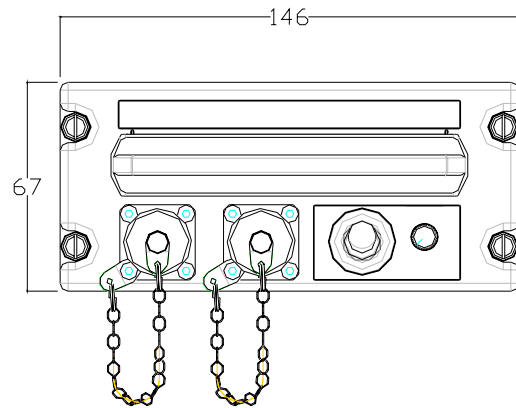
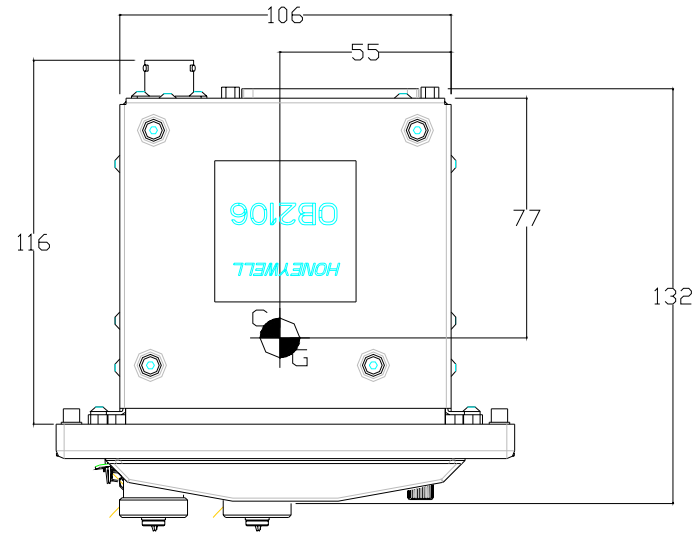

Observer Control Panel Connector Pin Assignment (Incorporating OB2106-001 & OB2106-002).

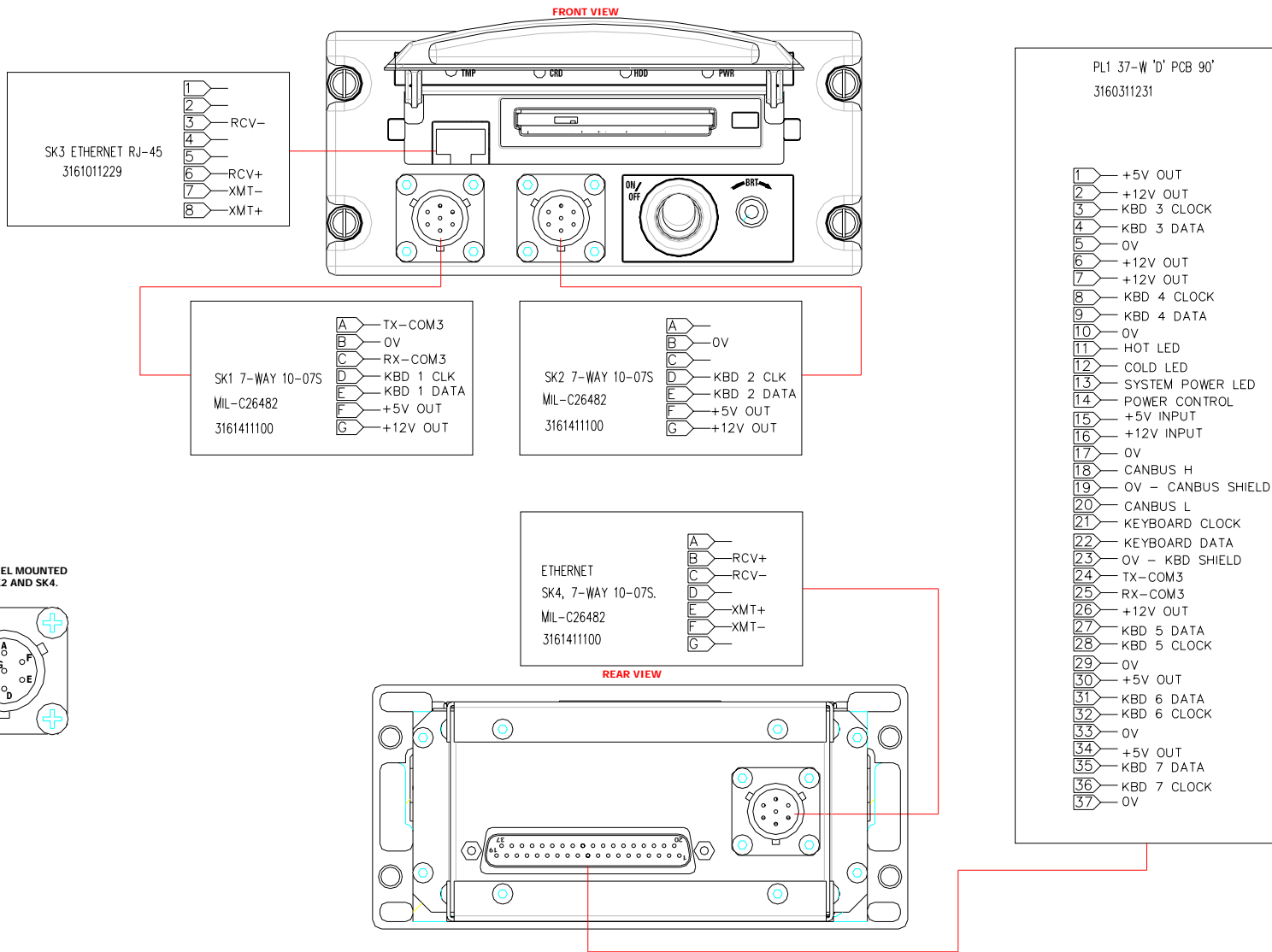

Observer Installation Wiring Schematic (Incorporating OB2101-001 and OB2101-002).

PROCESSOR: OB2101-001 (Mod1), OB2101-002 (Mod1)

OB1110-001

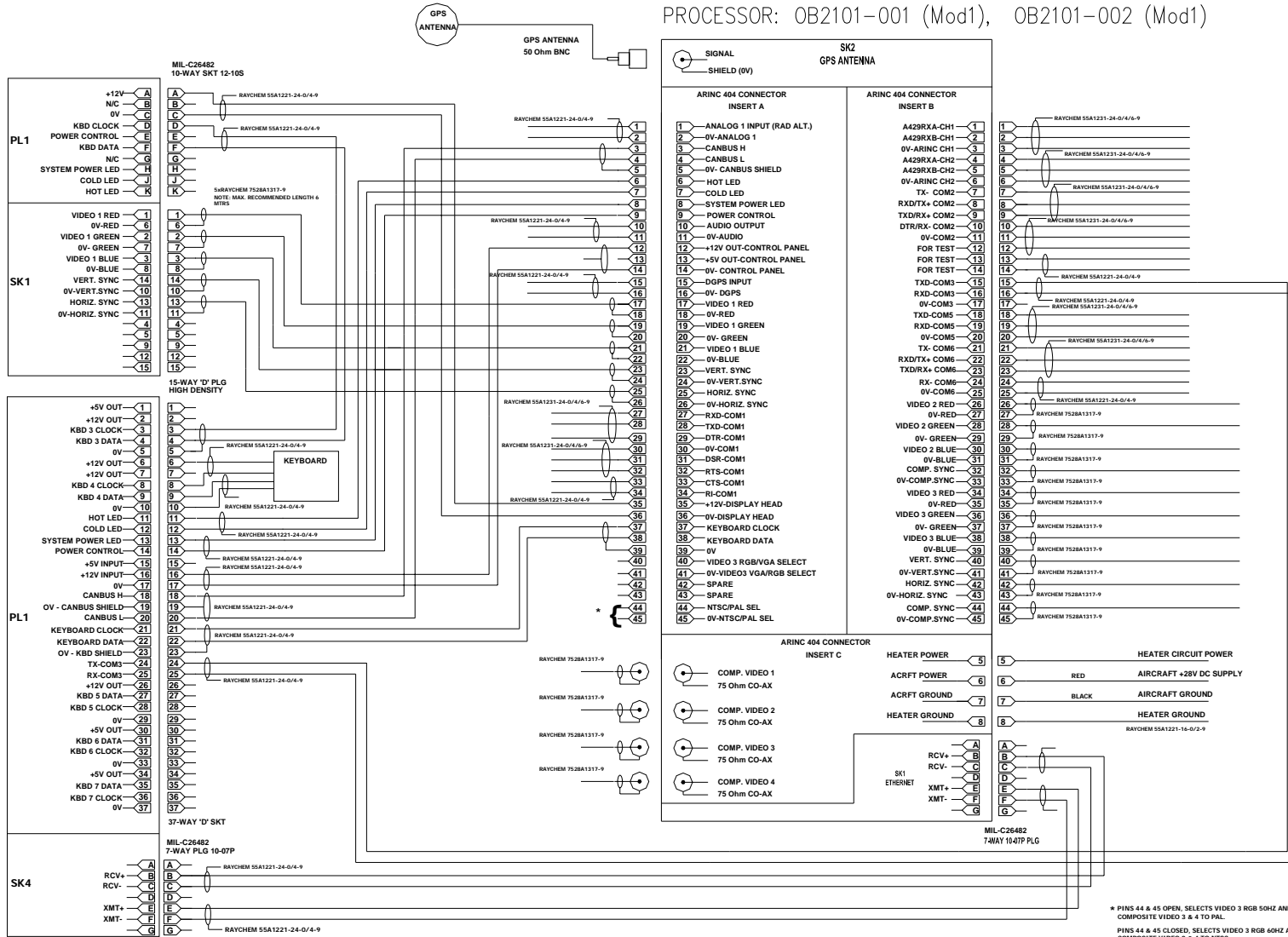

NOTE: 1. ENSURE YOU CORRECTLY IDENTIFY THE MODEL NUMBER OF THE PROCESSOR BOX AS DEFINED ABOVE, THIS IS A 2 SHEET DRAWING COVERING VARIOUS MODELS.

NOTE: 2. ALL CABLE SCREENS MUST BE TERMINATED AT THE PROCESSOR BOX RACK END ONLY EXCEPT WHERE CABLE SCREENS ARE SHOWN TO TERMINATE AT BOTH ENDS.

* PINS 44 & 45 OPEN, SELECTS VIDEO 3 RGB 50HZ AND COMPOSITE VIDEO 3 & 4 TO PAL.
PINS 44 & 45 CLOSED, SELECTS VIDEO 3 RGB 60HZ AND COMPOSITE VIDEO 3 & 4 TO NTSC.

Observer Installation Wiring Schematic (Incorporating OB2101-003).

PROCESSOR: OB2101-003

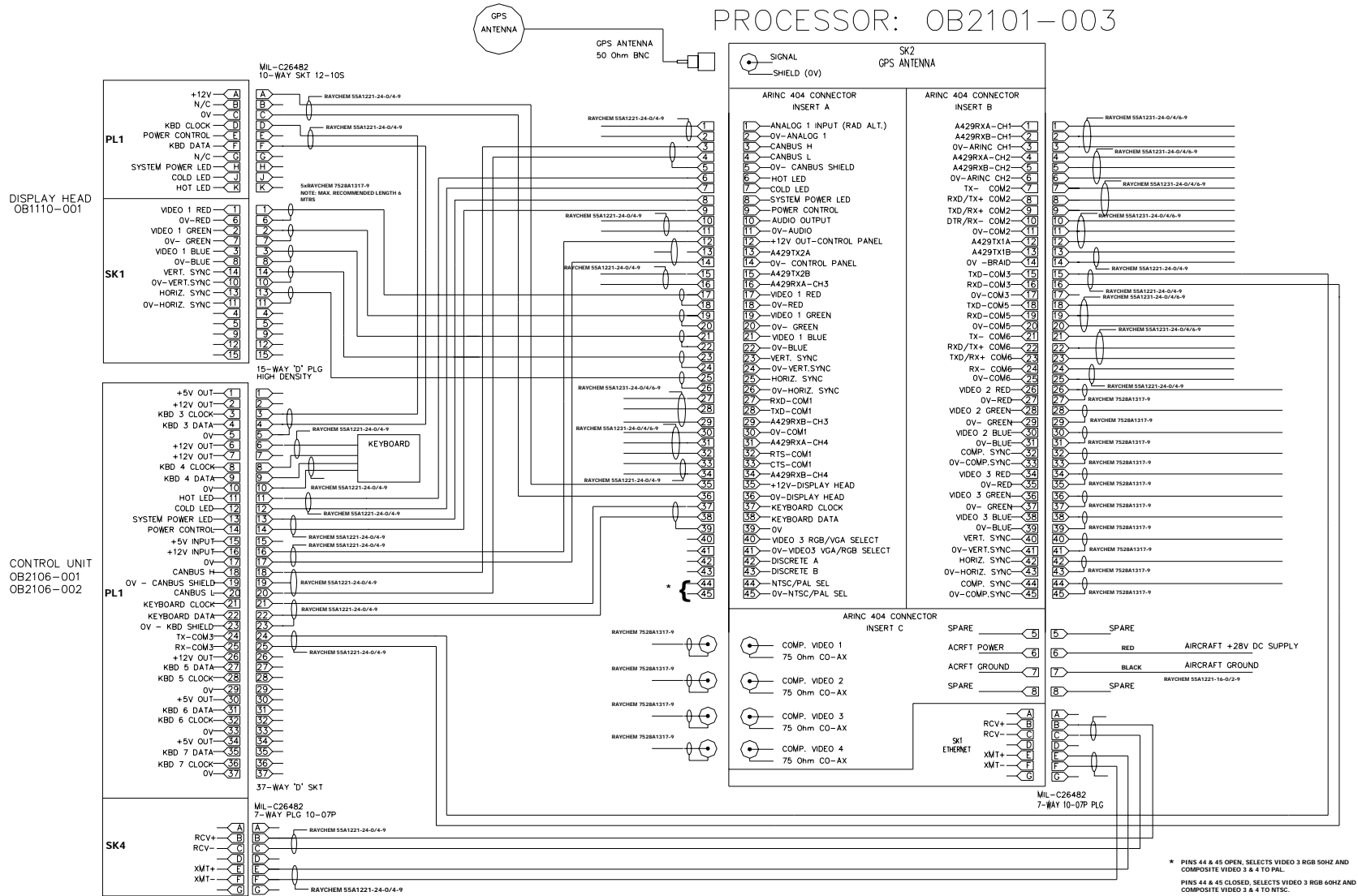

NOTE: 1. ENSURE YOU CORRECTLY IDENTIFY THE MODEL NUMBER OF THE PROCESSOR BOX AS DEFINED ABOVE, THIS IS A 2 SHEET DRAWING COVERING VARIOUS MODELS.

NOTE: 2. ALL CABLE SCREENS MUST BE TERMINATED AT THE PROCESSOR BOX RACK END ONLY EXCEPT WHERE CABLE SCREENS ARE SHOWN TO TERMINATE AT BOTH ENDS.

* PINS 44 & 45 OPEN, SELECTS VIDEO 3 RGB 50HZ AND COMPOSITE VIDEO 3 & 4 TO PAL.
 PINS 44 & 45 CLOSED, SELECTS VIDEO 3 RGB 60HZ AND COMPOSITE VIDEO 3 & 4 TO NTSC.

6 APPENDIX A - ENVIRONMENTAL

The below table defines the environmental test standard for the OB2000 System. Tests have been conducted at a suitable Test House to ensure traceability of all testing back to UK national standards.

6.1 SCHEDULE OF TESTS

RTCA/DO-160D Section	Category	Description
Section 4 – Temperature and Altitude	B1	Operating Low temperature = -20°C. Operating High temperature = +55°C. Short Term Operating High temperature = +55°C. Loss of Cooling temperature = +30°C. Ground Survival Low temperature = -55°C. Ground Survival High temperature = +85°C. Altitude = 15,000ft - declared
Section 4.5.4 - Loss of Cooling	V	30 minutes minimum @ +30°C.
Section 5 – Temperature Variation	B	5 degrees/min
Section 6 – Humidity	A	Standard Humidity
Section 7 - Operational Shocks and Crash Safety	B	Helicopter and Fixed Wing, Sustained 20g
Section 8 – Vibration	S, Y	Y is additional test to DO160-C Section 8
Section 9 – Explosion	X	Not required
Section 10 - Drip Proof	X	Not required
Section 11 – Fluid	X	Not required
Section 12 - Sand and Dust	X	Not required
Section 13 – Fungus	F	No test required (Non nutrient Materials)
Section 14 - Salt Spray	X	Not required
Section 15 - Magnetic Effect	Z	Less than 0.3 meters
Section 16 - Power Input	B	28V d.c. operation only. 50mS interrupt
Section 17 - Voltage Spike	B	Tested to B
Section 18 – AF Conducted Susceptibility-Power Inputs	B	Tested to B
Section 19 - Induced Signal Susceptibility	A	Tested to A
Section 20 - RF Susceptibility (Radiated and Conducted)	T	Tested to T
Section 21 - Emission of Radio Frequency Energy	B	Tested to B
Section 22 - Lightning Susceptibility	X	Not required
Section 23 - Lightning Direct Effects	X	Not required
Section 24 – Icing	X	Not required
Section 25 – ESD	X	Not required

END OF SECTION

7 APPENDIX B - WARRANTY

7.1 DEFINITIONS

For the clarification and avoidance of doubt the following definitions apply:

“Company” – means Skyforce Avionics Limited whose Registered Office is Honeywell House, Arlington Business Park, Bracknell, Berkshire RG12 1EB and whose normal place of business is 5 The Old Granary, Boxgrove, Chichester, West Sussex, PO18 0ES.

“Purchaser” – means the legal registered entity that is responsible for payment of the invoice for the supply of the equipment. In the instance that this is the end use customer, they shall ensure that the terms in the warranty are clearly communicated to the installer who has entered into a separate contract for the installation and commissioning of the equipment with the end use customer.

“End Use Customer” – means the individual or legal entity that the Purchaser has entered into a contract with to supply the system defined herein to in whole or part, i.e. in some instances the system will be delivered as a hardware platform excluding software/firmware.

“Equipment” – means the system in its entirety, i.e. parts, sub-assemblies, assemblies and all embedded software and firmware associated with the operation and use of the system.

7.2 STANDARD WARRANTY

The Company warrants that all of its products will at the time of delivery be free from defects in materials and workmanship and will conform to Company’s applicable specifications in force at the time of the sale. Company’s obligation herein shall be limited to, at the Company’s option, correcting, replacing or refunding the purchase price of any non-conforming product. This warranty does not cover costs associated with call out, removal, or on-site rectification of the equipment. Normal warranty service is repair and rectification free of charge at the factory or designated agent during normal working hours on a standard turn around time of 15 days. For enhanced services relating to maintenance and support these will be subject to negotiation with the end customer.

The Purchaser acknowledges that the warranty offered by the Company is deemed to be void if the equipment has been subjected to abnormal or excessive use, abused or misused in any way or if an unauthorised person has opened any of the equipment housings.

The Company shall not be liable for and the Purchaser shall indemnify and hold the Company harmless against any claim by or loss or damage to any person or property directly or indirectly occasioned or arising from the use or operation or possession of any equipment or goods supplied by the Company.

The warranty will commence from the date of invoice of the goods and shall be 24 months in duration, unless specifically agreed to be otherwise as part of the contract. The general warranty and its specific terms are transferable to the end use customer, excluding the refund of purchase price and subject to the restrictions and limitations specified within Company's Standard Terms and Conditions of Sale and the appropriate handbook supplied with the product. All warranty claims will be reviewed in accordance with the foregoing conditions.

The Purchaser has a duty of care to ensure that the terms of this warranty are communicated to the end use customer. By accepting the equipment the Purchaser is deemed to have accepted the obligation to flow down the Company's terms within this warranty.

7.3 MAINTENANCE

Either the Company or an authorised agent may undertake maintenance of the equipment inclusive of warranty action (subject to Company's prior approval). Company's criterion for authorised agents is that they are JAR/FAR145 Approved as a repair organisation for the equipment and form part of the Bendix/King Dealer Support Network, details of which are to be found at www.bendixking.com. A listing of authorised agents for the Company's product is published periodically on the web site, however the Purchaser is advised to confirm with the Company that the approval for the agents listed therein remains current should he require to make use of their services.

7.4 USE AND CONTROL OF DATA AND HARDWARE

The Purchaser, his authorised agents and the End Use Customer acknowledge that the use of the Company's equipment does not in any way eliminate, replace, supersede or in any way affect the need to consult, refer to or obtain information from all appropriate and applicable charts, publications or sources of information from relevant Air Navigation Authorities.

The data sources for the mapping contained within the system is derived from Jeppesen GmbH, Ordnance Survey Mapping© Crown Copyright and other third party sources all of which will be identified as part of the deliverable data/software embedded in the end-use equipment. In accepting the equipment the Purchaser automatically accepts the flow down non-exclusive, non-transferable licence terms associated with each and all the applicable aforementioned third parties. No representations as to the accuracy or currency of the data provided is expressed or implied in the

purchase of the equipment. The Purchaser will indemnify and hold harmless the Company against any third party or consequential claims arising either directly or indirectly through the use of the data and/or the equipment.

No part of the program in the memory of the equipment may be reproduced, transmitted, transcribed, translated or altered in any way, form or by any means, without prior written permission of the Company.

Without the prior written authorisation of Company, the Purchaser will not knowingly re-export or ship, or cause to be re-exported, exported or shipped directly, any technical data or hardware obtained from the Company to any destination defined as prohibited or controlled under the Export of Goods (Control) Order 1994, as amended from time to time by Her Majesty's Government by way of the Dual Use and Related Goods (Export Control) Regulations.

7.5 GOVERNING LAW

This Warranty shall be governed by English Law, any disputes arising out of any contract made between the Company and the Purchaser shall be heard and determined by an English Court of competent jurisdiction. Alternatively at the option of the Company, any claim shall be submitted to arbitration in England in accordance with and subject to the provisions of the Arbitration Act 1950 or any statutory modifications or re-enactment thereof for the time being in force.

END OF SECTION
